



# OPTIMA EST Series **USER'S MANUAL**

Operating &  
Maintenance Instructions



Manufactured by  
**SJE Corporation, Ltd.**



# **User's Manual**

Operating and Maintenance Instructions

Model : OPTIMA EST Series

Distributor's Contact:

*Published by SJE Corporation, Ltd.*  
Copyright © 2011 by SJE Corporation, Ltd.

San 225 Yelim-Li, Jeonggan-Myeon, Gijang-Gun  
Busan, Republic of Korea

**Tel** +82 51-521-3200

**Fax** +82 51-521-3305

**Website** <http://www.sjecorp.com>

**E-mail** [info@sjecorp.com](mailto:info@sjecorp.com)

*All rights reserved. No part of this publication may be reproduced,  
stored in a retrieval system, or transmitted, in any form or by any means, electronic, mechanical, photocopying,  
recording, or otherwise, without the prior permission of SJE Corporation, Ltd.*

# Table of Contents

Introduction . . . . .	1
Intended Applications . . . . .	1
Safety Precautions . . . . .	1
Symbols Key . . . . .	2
Specifications . . . . .	4
Parts Description . . . . .	5
Pre-start Procedure . . . . .	9
Automatic Feedwater System (OPTION) . . . . .	10
Starting the Optima for the First Time . . . . .	11
Standard Start-Up Procedure . . . . .	12
Moisture Control . . . . .	13
Pause Operations . . . . .	14
Shutdown Procedure . . . . .	14
Freeze Prevention . . . . .	15
Maintenance . . . . .	17
Safety Features . . . . .	21
Troubleshooting Guide . . . . .	23

## ***Introduction***

---

The Optima represents the future of environmentally friendly and effective cleaning. Safe, durable and easy to use, the Optima will support your cleaning operations for many years to come.

## ***Intended Applications***

---

The Optima Steamer is designed exclusively for cleaning vehicles, machines and general surfaces capable of handling steam jet pressure of up to 8 bar (116psi) and temperatures reaching 85°C-120°C (185°F-248°F).

The Optima Steamer has numerous applications; clean machinery, vehicle exteriors, interiors, engine compartments, windows, wheel wells, sterilize, deodorize, remove weeds and much more.

## ***Safety Precautions***

---



**Before operating the Optima for the first time, read the manual completely.**







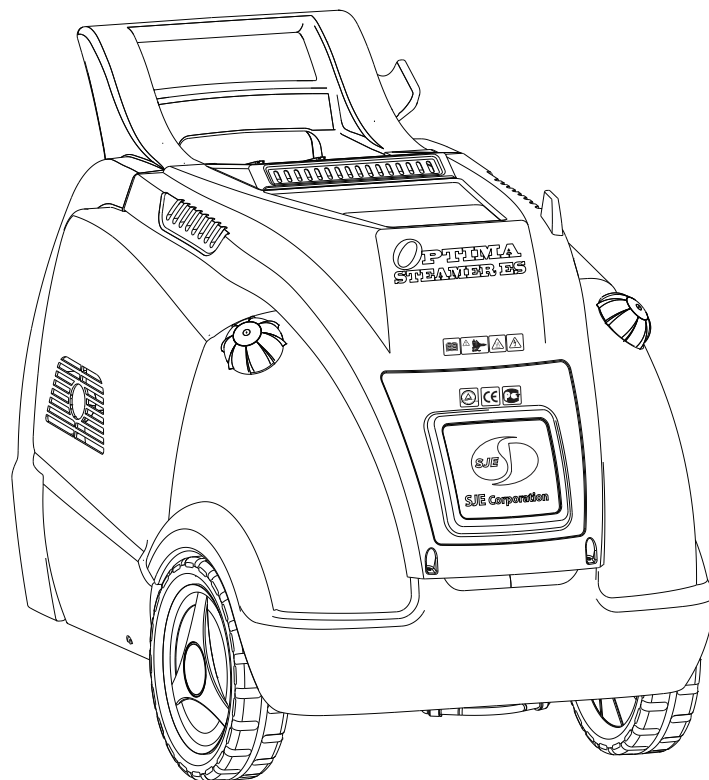







The manufacturer and distributors are not liable for mechanical troubles, property damage, or personal injury caused by the operator(s) unfamiliarity with the manual's instructions.

- With regards to the boiler, use only water and the manufacturer's recommended boiler cleansing solution. Do not put any other chemicals or detergents into the water tank or boiler.
- Do not use distilled or de-ionized water.
- Use only clean tap water. "Soft" water is recommended.
  
- The electric supply connection should be made by a qualified electrician and complied with IEC 60364-1.
- EST(1) : Make sure that all the switches on the machine are off before plugging the machine into an electrical outlet.
- EST(3) : Make sure that all the switches on the machine and the three-phase breaker switch in the electric panel board is off before connecting the machine to the breaker. Connect the power cable R, S, T, and ground cable to the breaker and then turn on the breaker switch.
- If an extension cord is used, insure that it is of watertight construction and of proper diameter based on the cord length and required electrical specifications.
- Turn off the Power switch when refilling the water tank.
- Unplug the Optima from its power source and allow the Optima to cool before carrying out maintenance.
  
- Use only hoses, fittings and couplings recommended by the manufacturer.
- Use only spare parts approved by the manufacturer.







- 
- Use and store the Optima on a leveled surface.
  - Do not use the machine in rain or snow. The Optima Steamer is not weather-proof.
  - Never leave the machine running unattended.
  - Never store or leave the machine unattended below 32°F (0°C).
  - In cold climates, do not allow water to sit when the Optima is not in use (See page 15). Do not operate the Optima if any part is frozen or suspected of being frozen.
  - Do not use the Optima if any part, power cord, safety device, hose or spray gun is visibly damaged or suspected of being damaged.
  - Use proper ear, eye and hand protection when operating the Optima. Noise generated from steam pressure can reach 95 decibels (dB).
  - Do not use the appliance within the range of persons not wearing protective clothing.
- 
- Do not direct the steam jet spray or discharge at self, live electricity, people or animals.
  - The appliance is not to be used by children or persons with reduced physical, sensory or mental capabilities, or lack of experience and knowledge, unless they have been given supervision or instruction.
  - Keep the Optima away from children and animals at all times.
  - Children should be supervised to ensure that they do not play with the appliance.
- 
- Never disable a sensor in order to bypass an alarm.
  - To provide continued protection against risk of electric shock, connect properly to grounded outlets only.



## Symbols Key

	Do not direct the steam jet at people, live electricity, animals, etc.		Read the manual.
	Warning: risk of burns.		Water pump.
	Water supply.		Warning: risk of electric shock.
	Water connection.		Use caution.
	Pressure gauge.		Ground.
	Thermostat.		Main power.
	Electric Heater		Steam jet.

### LED Lamp and Alarm Indication

	Main POWER lamp on.		Water pump run lamp on
	Water level lamp on		Water level lamp blinking.
	Alarm beeps once.		Alarm sounding continuously.

## Specifications

Model	Optima EST3	Optima EST1	Optima EDS
Working Pressure	8 bar / 116 psi (Max. 10 bar / 145 psi)		
Working Temperature	< 100°C / 212°F		
Boiler Temperature	174°C / 346°F (Max. 180°C / 356°F)		
Preheating Time	6 ~ 7 minutes	19 minutes	6 ~ 7 minutes
Rated Electric Power	12.0 (12.2 Max.)Kw	5.0 (5.2 Max.)Kw	12.0 (12.2 Max.)Kw
Voltage / Hertz	220 ~ 480V, 3Ph, 50/60 Hz	220 ~ 240V, 1Ph 50/60 Hz	220 ~ 480V, 3Ph, 50/60 Hz
Water Tank Capacity	40 ℓ / 10.6 gals		17 ℓ / 4.5 gals
Water Consumption Rate (Max)	600 cc/min (0.165 gpm)	300 cc/min (0.08 gpm)	600 cc/min (0.165 gpm)
Net Weight	73.5 kgs / 162 lbs		85 kgs / 187 lbs
Net Dimensions	109 x 70 x H90 cm (43" x 28.3" x H35.4")		78 x 50 x H76 cm (43" x 28.3" x H35.4")

### Note!

- \* To ensure safety and machine effectiveness, do not alter the preset steam pressure and temperature settings.
- \* Moisture content in the steam can be adjusted by the moisture control valve. (See page 13)

### Water Quality Matters!

Water quality can greatly affect the Optima's life span and performance. It is important to use clean tap water or soft water. Daily use of water treatment and regular scale removal will help ensure efficient operations (see "Maintenance" for more information), and using a water softener is also recommended.

**Do not use distilled or de-ionized water. Do not put any other chemicals or detergents into the water tank or boiler.** The water temperature should be above 5°C (40°F).



# Parts Description

Left side - Top – Back

Fig.1

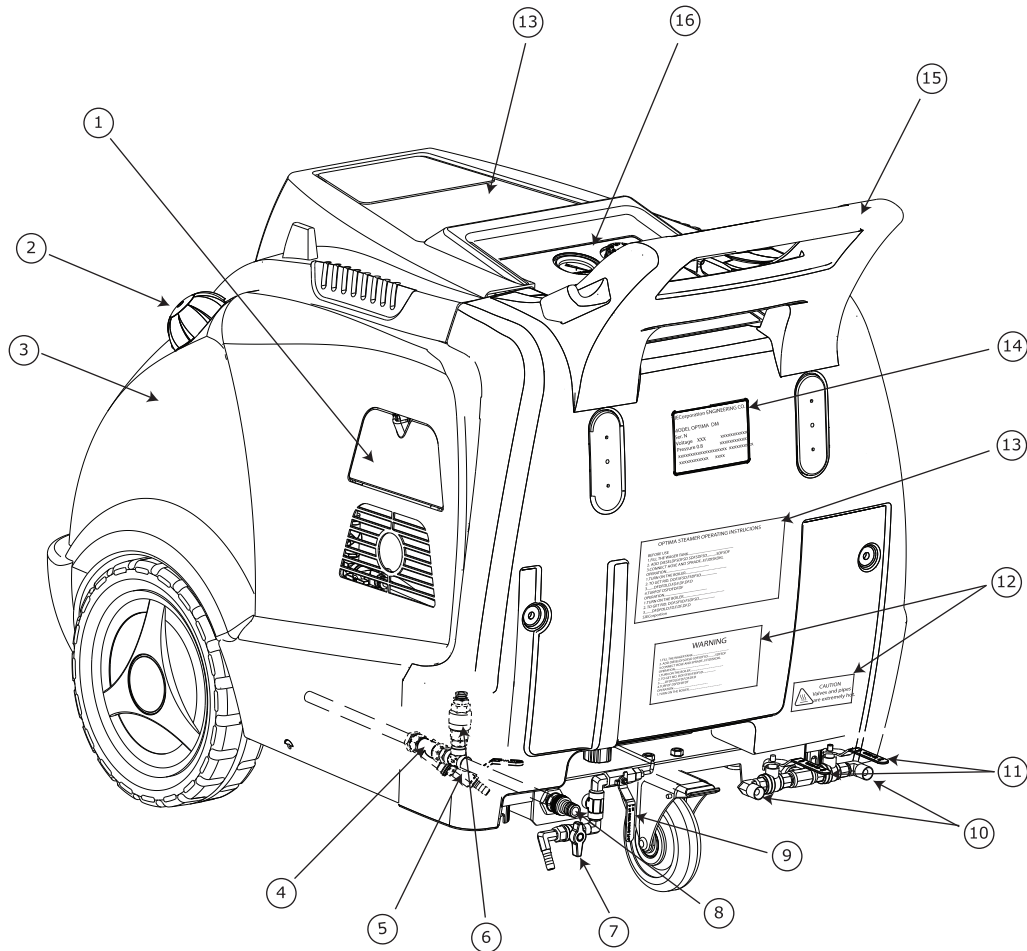

- ① Throttle door
- ② Tank cap
- ③ Water tank
- ④ Y-strainer
- ⑤ Drain valve
- ⑥ Non-return valve
- ⑦ Drain valve
- ⑧ Plug for Coupling

- ⑨ Moisture control valve
- ⑩ Steam outlet
- ⑪ Steam outlet valve
- ⑫ Warning stickers
- ⑬ Operating instructions
- ⑭ Name plae
- ⑮ Handle
- ⑯ Control panel

Fig.2

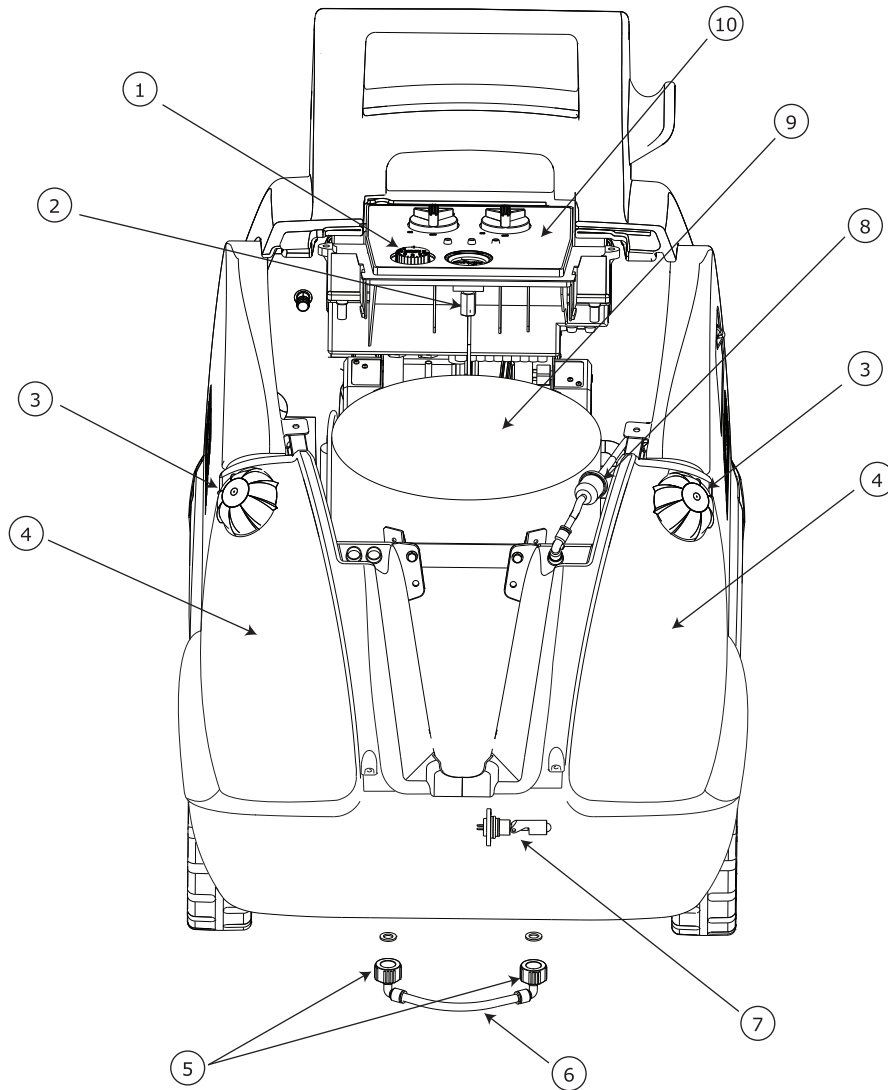

- |                  |                   |
|------------------|-------------------|
| ① Thermostat     | ⑥ Connecting pipe |
| ② Pressure gauge | ⑦ Float switch    |
| ③ Tank cap       | ⑧ Water filter    |
| ④ Water tank     | ⑨ Boiler          |
| ⑤ Drain cap      | ⑩ Control box     |

Fig.3

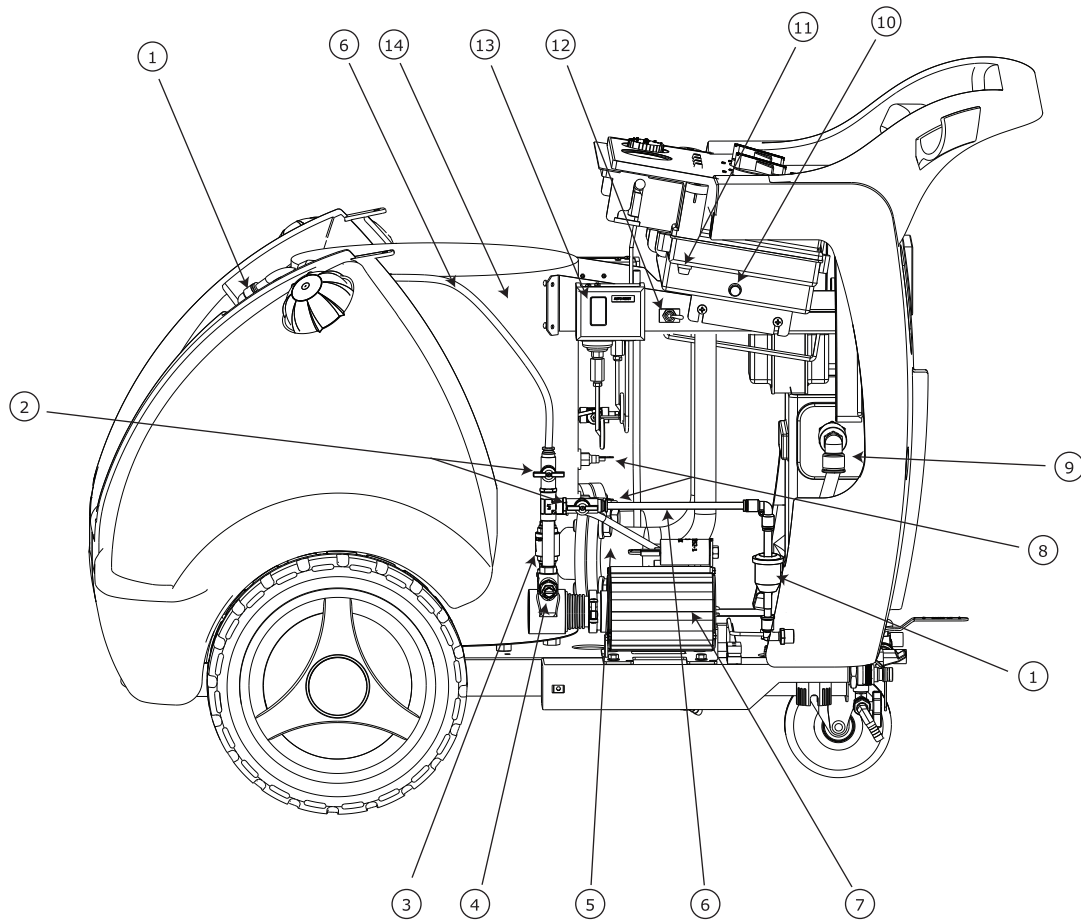

- |                          |                            |
|--------------------------|----------------------------|
| ① Water filter           | ⑧ High & Low probe sensors |
| ② Select valves (Option) | ⑨ Rear water tank          |
| ③ Non-return valve       | ⑩ Red button               |
| ④ Water pump             | ⑪ Fuses                    |
| ⑤ Electric heater        | ⑫ Select switch            |
| ⑥ Water suction line     | ⑬ Pressure switch          |
| ⑦ Motor                  | ⑭ Boiler                   |

Fig.4

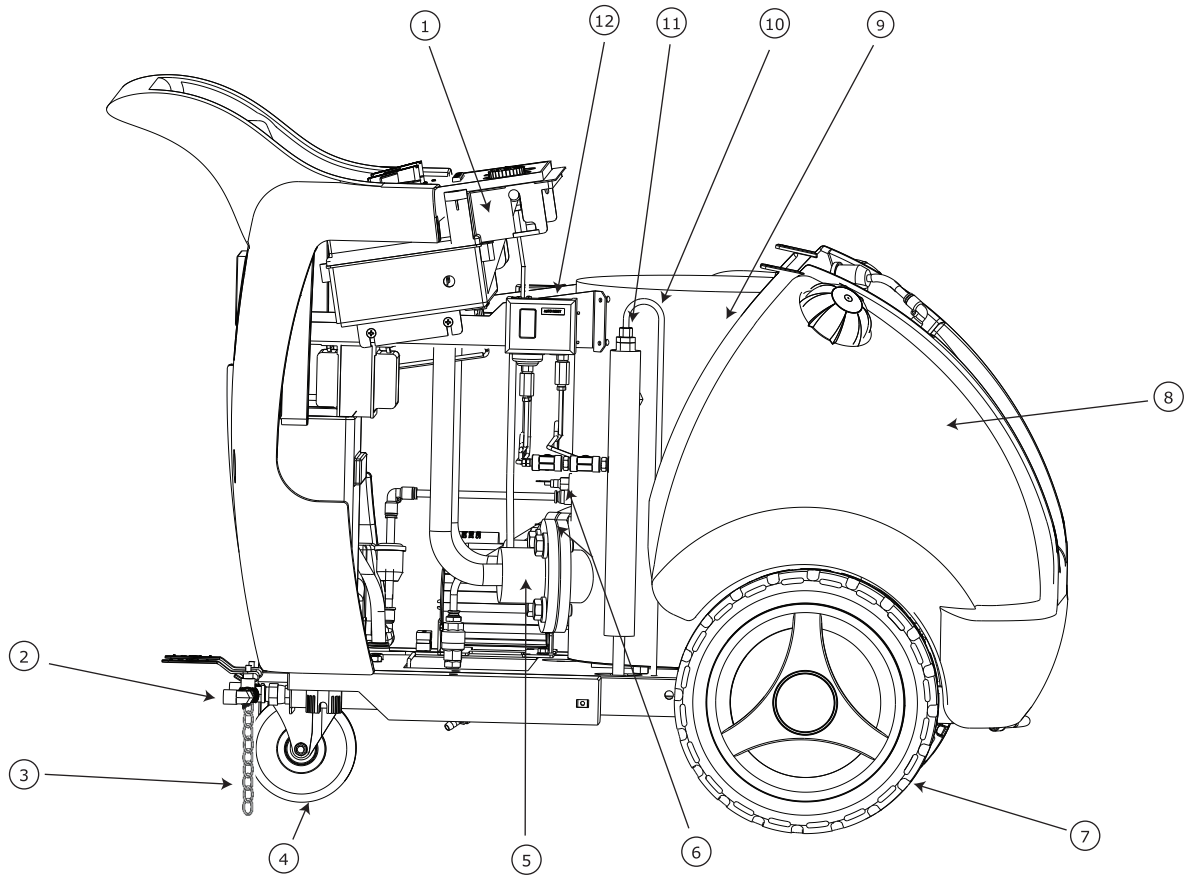

- |                            |                   |
|----------------------------|-------------------|
| ① Control box              | ⑦ Wheel           |
| ② Steam outlet             | ⑧ Water tank      |
| ③ Grounding chain          | ⑨ Boiler          |
| ④ Turning wheel            | ⑩ Copper pipe     |
| ⑤ Electric heater          | ⑪ Safety valve    |
| ⑥ High & Low probe sensors | ⑫ Pressure switch |

## ***Pre-start Procedure***

---

### **Steps**

1. Connect the steam hose and gun to the steam outlet. Insure a tight connection (use wrench) (Fig. 5).
2. Fill the water tank with tap water (Fig. 6). Add recommended dosage of **water treatment** to the water tank. Do not use distilled or de-ionized water.

#### Automatic feedwater device( Option)

When water is being supplied by a hose in the stationary position, open the throttle panel and change the select switch and the water suction valves to "F" from "M" simultaneously (Fig. 7 ~ 8).

Through the throttle door, add a daily dose of water treatment to the rear water tank. Connect a hose to the hose fitting located at the bottom of the rear water tank (Fig. 7).

3. Connect the machine to an electric power source.
  - EST(1) : Make sure that all the switches on the machine are off before plugging the machine into an electrical outlet.
  - EST(3) : Make sure that all the switches on the machine and the three-phase breaker switch in the electric panel board is off before connecting the machine to the breaker. Connect the power cable R, S, T, and ground cable to the breaker and then turn on the breaker switch.

Fig.5

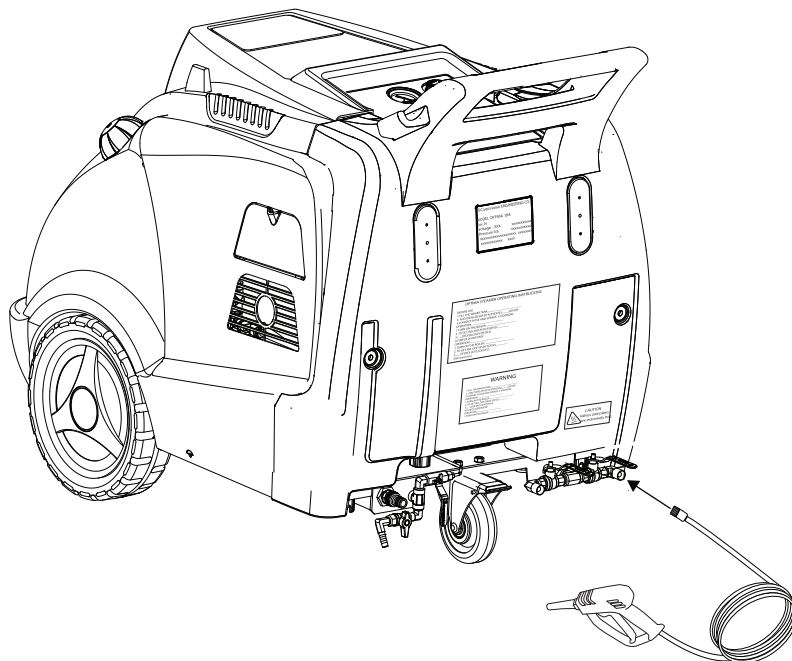

## Automatic Feedwater System (OPTION)

Fig.6

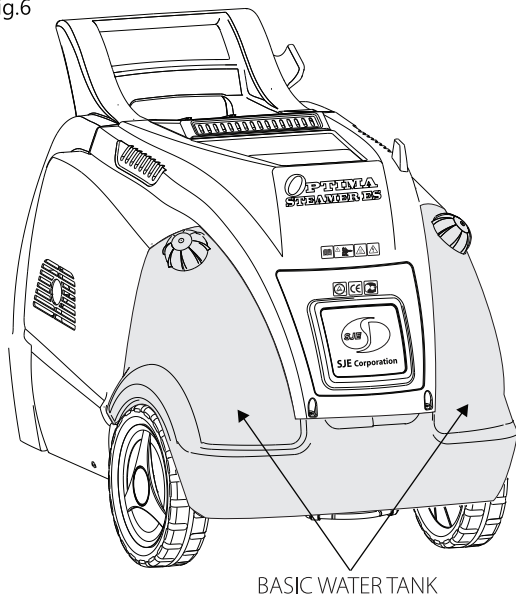

Fig.7

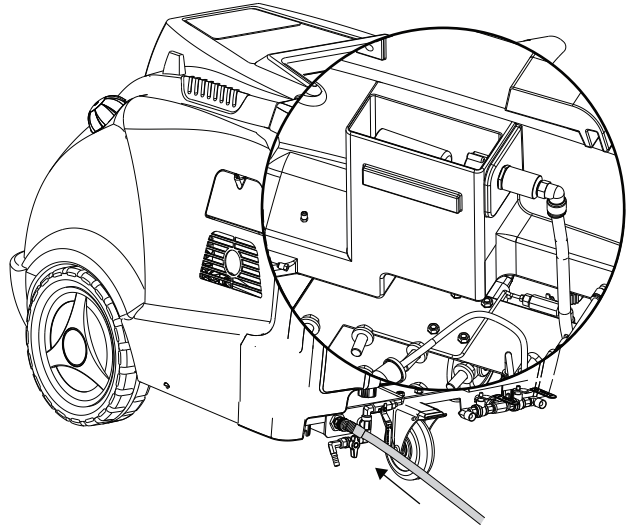
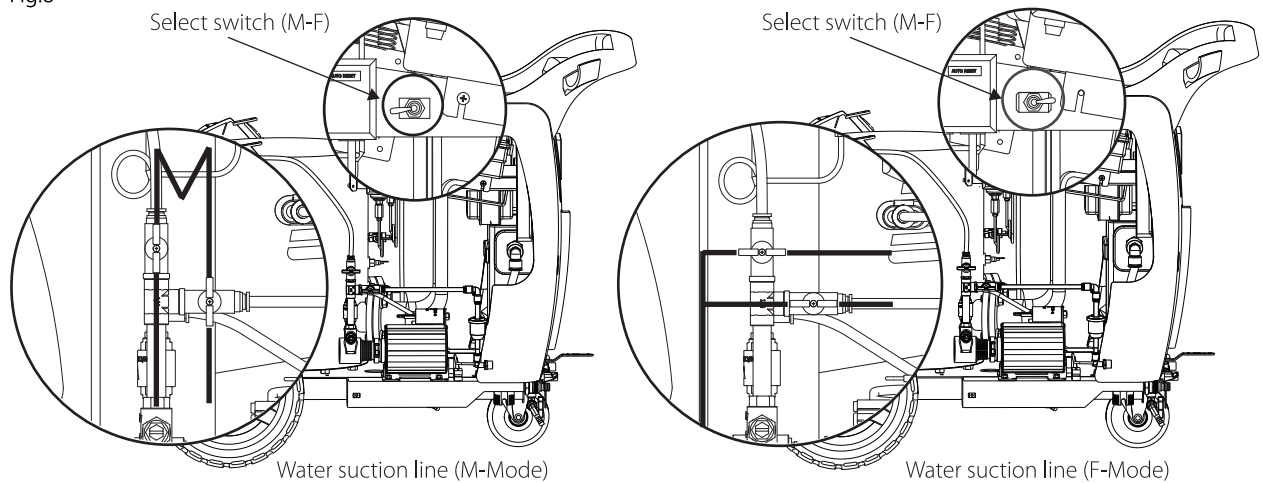

Fig.8



### Boiler Water Treatment

Scale caused by impurities in water can build up inside the wall of the boiler vessel. The scale build-up can greatly impact boiler longevity and operating efficiency.

Adding the recommended water treatment and draining the boiler water on a daily basis will help prevent scales from forming on the inside wall of the boiler vessel, protect against sensor malfunction, and increase the boiler's heat efficiency and longevity.

(See "Maintenance" A & B on page 17)







Only use water treatment approved by your distributor and the manufacturer.

## Starting the Optima for the First Time

The low water probe sensor in the boiler vessel vastly controls the machine's operations (Fig. 11). Because a new machine does not contain water in the boiler vessel, the low water probe sensor will set off the alarm when the machine is turned on.

**After completing the pre-start procedure, follow the steps below.**

● lamp on    ✨ lamp blinking    🔊 alarm sound

Steps	Instructions	Signal indications
1	Make sure the water tank is full. The initial start-up will consume more water because the boiler vessel is empty. The pressure in the boiler could go up as the water is fed into the boiler and the existing air in the boiler has no way out. To let the air out, open the steam outlet valve and pull the steam gun trigger until #5 is confirmed.	
2	<b>Turn on the POWER switch. You will see either A , B, or C signal indications.</b> A : All LED lamps will be on. The alarm will sound for about 1 minute while the water pump supplies water to the boiler vessel. B : If the float switch in the water tank does not detect water, you will see only the POWER lamp on and hear the alarm sound. Add water to the water tank.	<p>A </p> <p>B </p>
3	<b>If the alarm continues after 1 minute, you will see either A or B signal indications.</b> A : The low water probe sensor (minimum water level required) has not detected water. Reset the POWER switch and wait until the alarm clears. B : The boiler vessel now contains enough water to activate the boiler. Reset the POWER switch.	<p>A </p> <p>B </p>
4	The alarm will stop. In addition to the POWER lamp, the Pump Run lamp will remain on until the high water probe sensor (allotted maximum water level) in the boiler vessel detects water.	
5	Only the POWER lamp will remain on once the high water probe in the boiler vessel detects water. <u>Continue to Step #2 of "Standard Start-up Procedure" on the next page.</u>	

### Note!

When using the Optima after draining the boiler vessel, the above procedure must be repeated.

# Standard Start-Up Procedure

Fig. 9

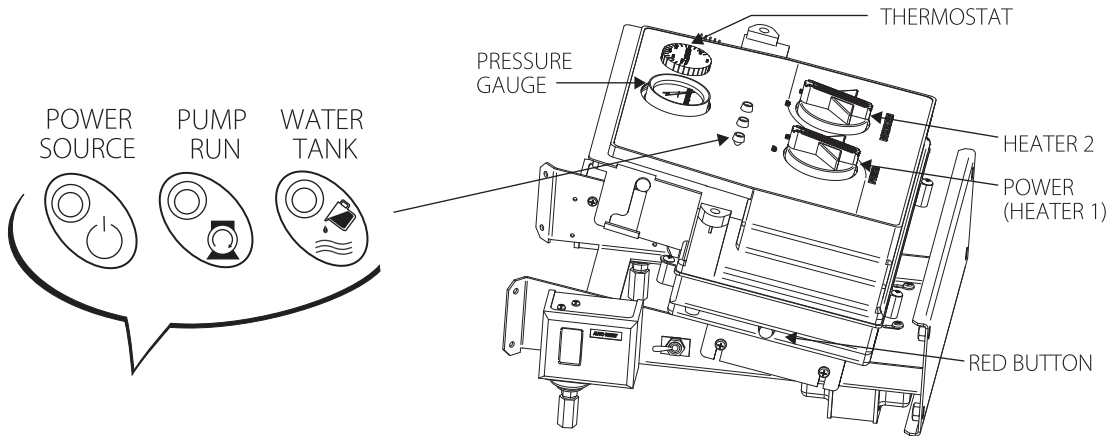

## Steps

1. Turn the POWER (HEATER 1) switch on, and you will hear the beep once and see only the power lamp on. (If you are starting the Optima for the first time or using after draining the boiler vessel, refer to "Starting the Optima for the First Time" on the previous page.)
2. Turn the HEATER 2 switch on.
3. Remove air in the boiler. If the pressure gauge (Fig. 9) needle is bouncing up and down, or if you can hear a knocking sound, this is an indication that air exists in the boiler vessel. To remove air in the boiler vessel, open the steam outlet valve (Fig. 1-11) and pull the steam gun trigger until low pressure steam is visible. When you use one steam hose and the gun, open the idle steam outlet and leave the hose-connected one closed. Once you see the low pressure steam coming out, close the valve.
4. After the steam pressure reaches 8 bars, open the steam outlet valve and begin washing.



Review all safety precautions on page 1~2. Never leave the machine unattended.

Fig. 10

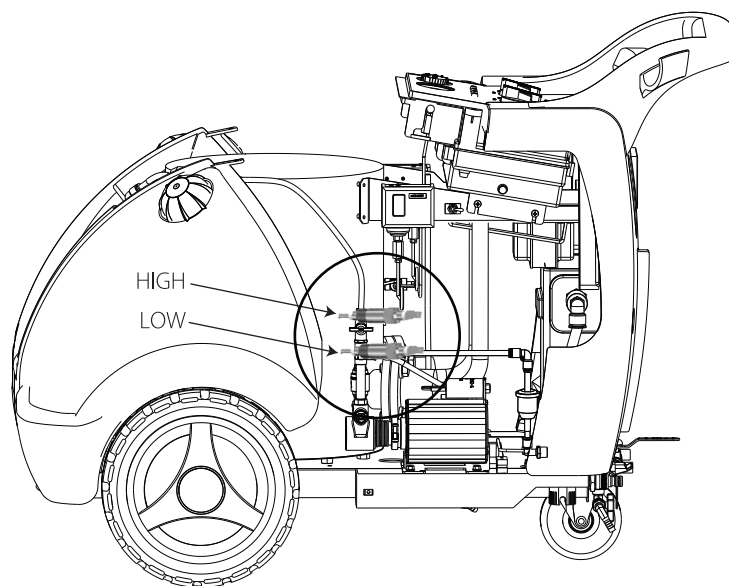

High & Low Water Probe Sensors



## ***Moisture Control***

---

You can increase the moisture content in the steam by opening the moisture control valve. Increasing the moisture content in the steam increases water consumption and may produce water run-off (Fig. 11).

Dry steam may persist due to extremely hot weather; adjust the moisture control valve accordingly. When cleaning and/or sterilizing interior surfaces, insure that the moisture control valve is closed to minimize surface wetness.

### **Note!**

In extremely hot weather, using two spray guns with the moisture control valve open all the way may consume steam faster than what can be replenished. The alarm will sound. Close the moisture control valve by 1/3 and allow pressure to build.

Fig. 11

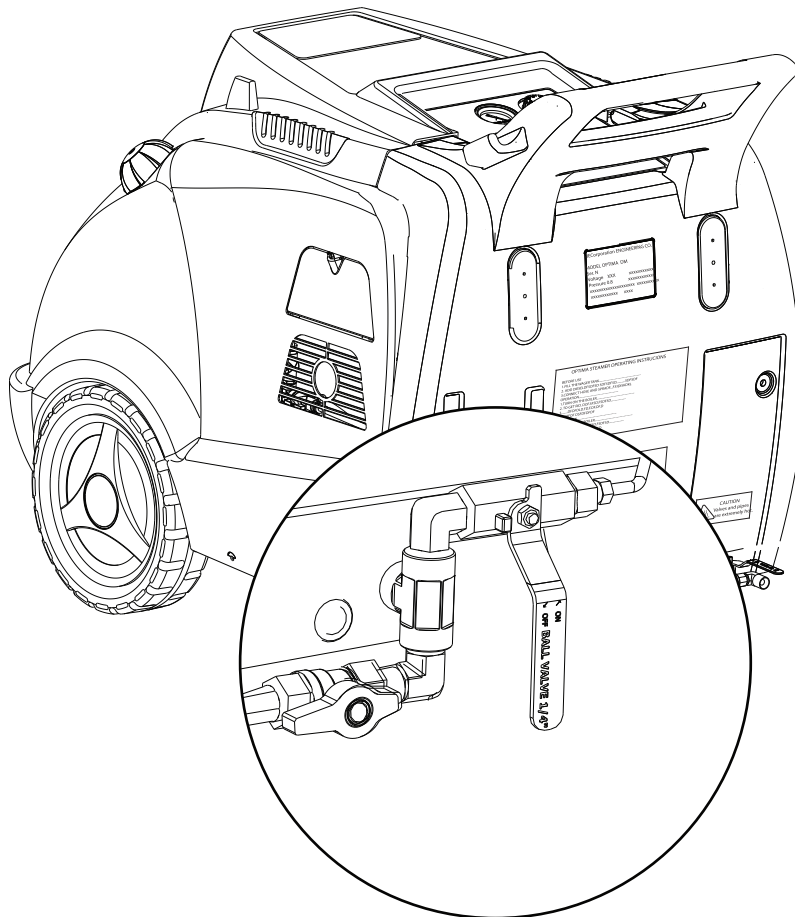

## ***Pause Operations***

---

### **Steps**

1. Turn the HEATER 2 switch off, and then POWER (HEATER 1) off.
2. Close the steam outlet valve and pull the steam gun trigger to release any remaining steam in the hose. This will prevent the release of water (cooled steam) and increase the life span of the steam hose and gun.

### **Note!**

When refilling the water tank, turn the HEATER 2 and then POWER (HEATER1) off. After refilling the water tank, turn the switches back on (POWER first and then HEATER2). Resume operation.

## ***Shutdown Procedure***

---

### **Steps**

1. Turn the HEATER 2 switch off, and then POWER (HEATER 1) off.
2. Use up the existing steam in the boiler vessel until the pressure drops to 2 bar
3. Drain the water in the boiler by opening the boiler drain valve (Fig.1-⑦). If the water from the boiler vessel is milky, drain all remaining water of the boiler vessel by opening the Y-strainer drain valve (Fig.1-⑤).
3. Close the steam outlet valve and pull the spray gun trigger to release the remaining steam in the hose. This will prevent the release of water (cooled steam) and increase the life span of the steam hose and spray gun.
4. In cold climates, additional steps are required to prevent damages (See "Freeze Prevention" on page 15~16).

### **Tips!**

#### **Extend the life span of the Optima**

1. Use clean tap or soft water.
2. Use water treatment daily.
3. Always remove air from the boiler vessel before use.
4. Always remove steam from hoses, spray guns, and the boiler vessel after use.
5. Store the Optima at room temperature.
6. Remove hardened scale from the boiler regularly by performing de-scaling (pg. 19~20).
7. Remove softened sludge from the boiler regularly (pg. 17).

# Freeze Prevention



In cold climates it is necessary to store the Optima in an area where the temperature is above freezing. Unplug the machine from electrical source and follow steps below to protect the Optima against ruptured lines and damage caused during cold climates. .

## Steps

1. Empty the boiler vessel.  
Slowly open the Y-strainer valve (Fig. 12) and boiler drain valve (Fig. 1-⑦) when the pressure is between 1 and 2 bar.]  
Keep both valves open until next use.  
The Y-strainer drain valve is reachable through the throttle door. (Fig. 1-①)



Steam is extremely hot.  
Wear appropriate hand and eye protection.

Fig. 12

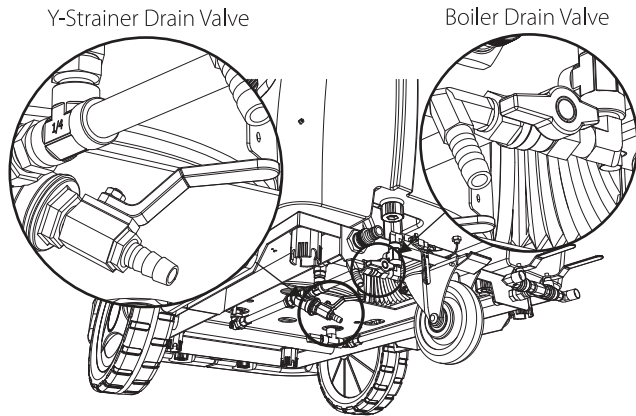

2. Empty the water tank.  
Open the water tank drain cap (Fig. 13 & 14).

Fig.13 M-mode

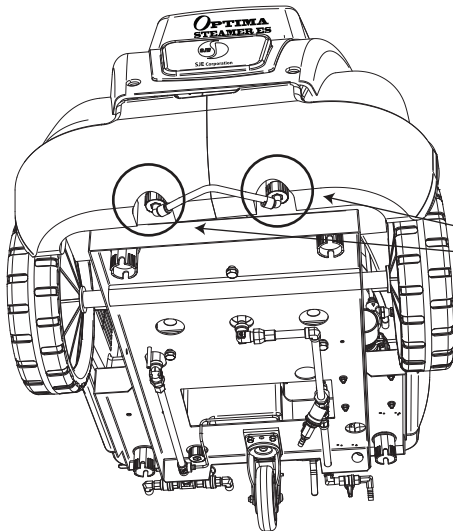
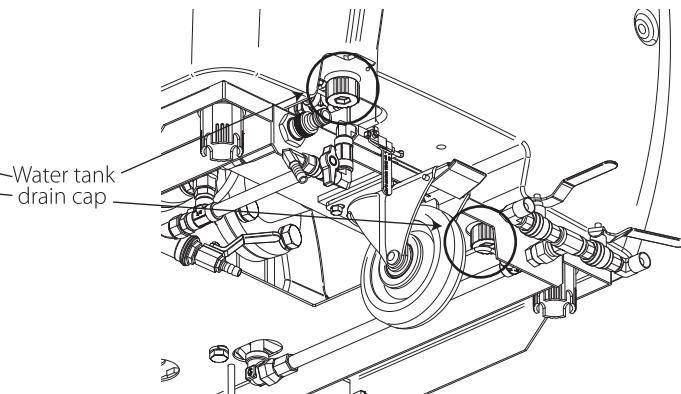
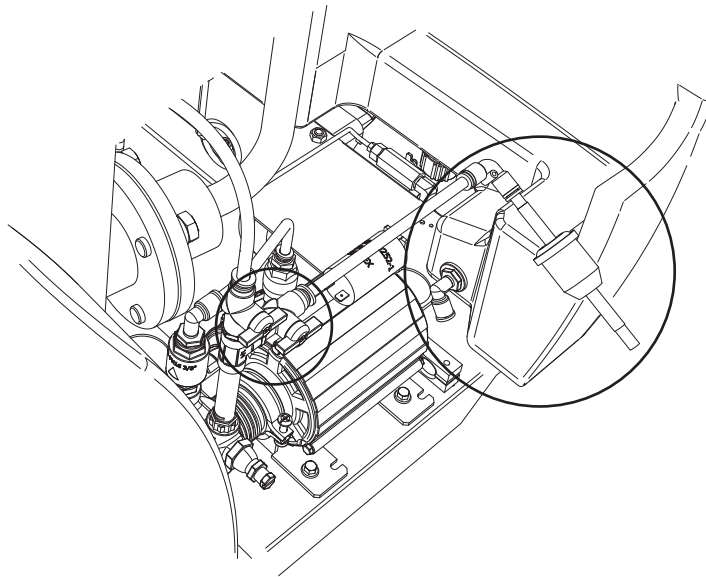

Fig.14 F-mode → OPTION



When the machine is being used at "F" mode (Fig. 8), drain all remaining water from the rear ter tank by detaching the water suction line (F) from the rear water tank (Fig. 15). Keep the line detached until next use.

Fig. 15



3. Empty the water suction lines and the water pump.

Fig. 16

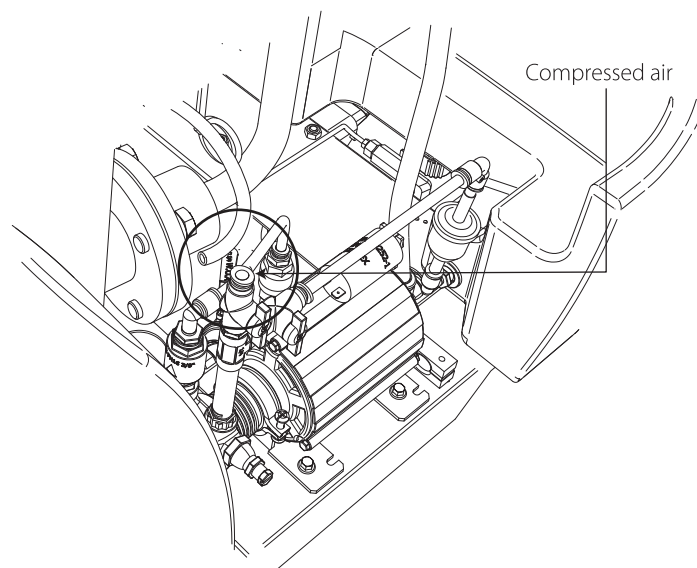

Detach the water suction line (M) from the water pump and remove the remaining water inside the water pump using compressed air or a blowing unit (Fig.16). Leave the line detached until next use.

4. Store the machine at room temperature.

**Note!**

Frozen water can rupture lines, cause malfunctions and destroy parts.

**Never** operate the Optima if any part is frozen or suspected of being frozen. Thaw the machine at room temperature. Carefully inspect the machine. If the machine is visibly damaged or performs abnormally, immediately turn off the machine and contact your distributor.

# Maintenance

**Note!**

Allow the machine to cool off before conducting maintenance.  
 Wear appropriate safety protection.  
 Unplug the machine from electrical source.  
 See page 27 for instructions on disassembling the exterior covers.

**Maintenance Schedule**

	Maintenance Items	Daily	Monthly	12Months
A	Add water treatment.	✓		
B	Check / drain boiler water	✓		
C	Drain water tanks.		✓	
D	Check water filters.		✓	
E	Check/clean water probe sensors.		✓	
F	Remove hardened scale in boiler.			✓

**A. Add water treatment.**

Add the recommended dosage of water treatment into the front or rear water tanks.  
 (See "Pre-start Procedure" Step #2 Page 9)

Boiler scale is caused by impurities in the water, settling on the inside wall of the boiler vessel. The build-up of scale can greatly impact boiler longevity and operating efficiency. Adding the recommended water treatment will help prevent scales from forming on the inside wall of the boiler vessel, protect against sensor malfunction, and increase the boiler's heat efficiency and longevity.

Only use water treatment recommended or approved by the manufacturer or your distributor.

**B. Check / drain boiler water**

Open the boiler drain valve (Fig. 1-⑦) and check the color of the water. If the water is milky, drain all remaining water from the boiler vessel by opening the Y-strainer drain valve (Fig. 1-⑤) or Y-strainer cap.

C. Drain water tanks. Contaminates can settle to the bottom of water tanks. Remove the drain caps from both tanks (Fig. 17).

D. Check the water and fuel filters routinely and replace if needed (Fig. 18).

Fig. 17

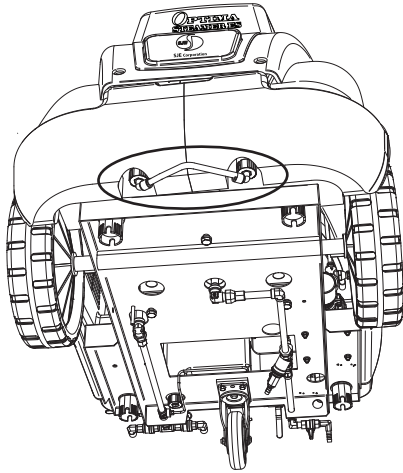
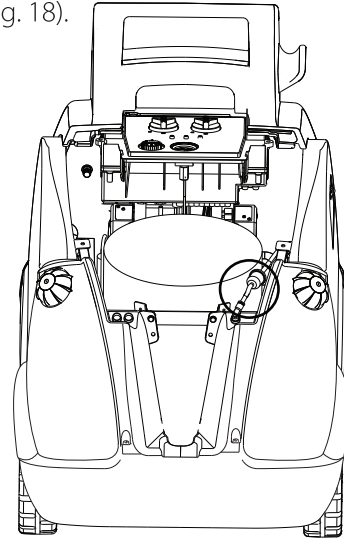

Fig. 18



E. Check/clean water probe sensors.

The Optima has two water level probe sensors (low and high) (Fig.10). Mineral build-up and scale on the water probe sensors can affect sensor accuracy.

**What you will need:** screw driver (+), 14mm deep socket wrench or double wrench (Do not use a torque wrench or power tools), sandpaper, and Teflon tape.

### Steps

1. Unplug the machine and let the steam pressure drop to the bottom.
2. Drain the boiler vessel by opening the boiler drain valve (Fig. 1-⑦).
3. Remove the front cover (See page 27) and disconnect the sensors from wiring.
4. Remove the sensors from the boiler using 14mm deep socket wrench.
5. Using sandpaper, scrub the sensors clean. Replace them if necessary.
6. Wrap the threads of the sensors with Teflon tape and reassemble the sensors using the tool.

### Testing the low water probe sensor (RED BUTTON)

As one of the machine's safety features, the low water probe sensor in the boiler vessel vastly controls the machine's operations. If the sensor does not detect water, the machine's CPU shuts off the boiler and sets off the alarm. To confirm the low water probe sensor is not functioning due to hardened scale, a malfunction, or water temperature below 5 °C, turn on the POWER switch while the red button is pushed down (Fig. 19).

Do **not** push the button for longer than 10 seconds when the POWER switch is on. If the alarm stops, this means the sensor cannot detect water despite its presence in the boiler vessel. If this occurs, the high and low water probe sensors need to be cleaned or replaced, or the water temperature should be increased above 5 °C.

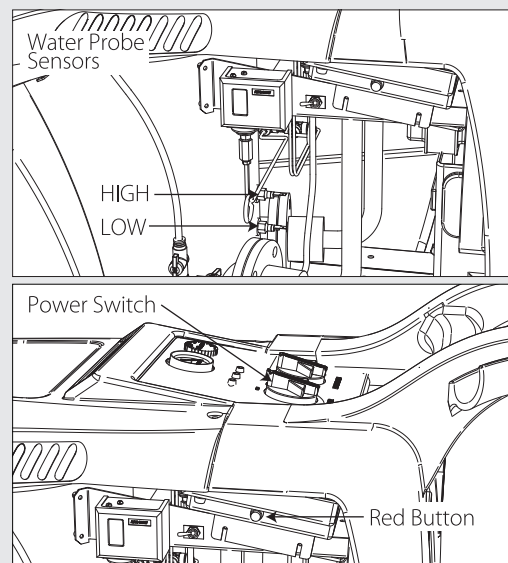

F. Remove hardened scale in boiler vessel.

What you will need : screw driver (+), wrenches, 10mm Tee-box wrench, 14 liters of diluted de-scaling liquid, and 2 liters of clean tap water.

### Steps

1. Remove the front and left side covers (Page 27).
2. Open the Y-strainer drain valve (Fig. 1-⑤) and release all water from the boiler. Close the Y-strainer valve afterwards.
3. Open the steam outlet valve of the side which is not connected with the steam hose (Fig.20).
4. Disconnect the high water probe sensor from wiring (Fig.21) and ensure the water tank is full.

Fig. 20

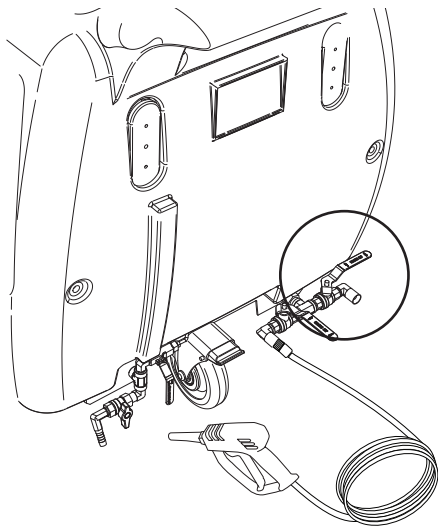
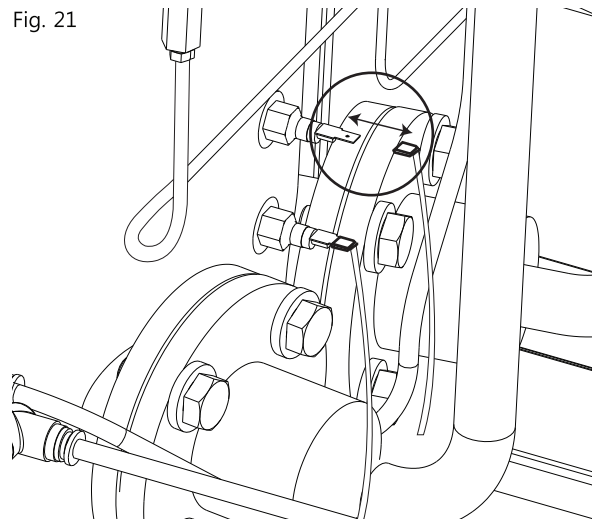
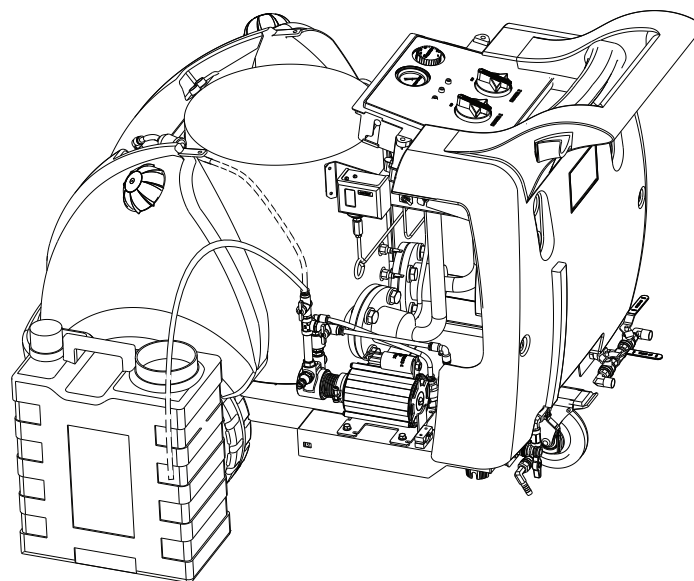

Fig. 21



5. Detach the water suction line from the water filter and submerge the tip into the container filled with 14 liters of diluted de-scaling liquid (Fig. 22))



- 
6. Turn on only the POWER (HEATER 1) switch to activate the water pump. For safety reasons the water pump is designed to stop after 1 minute of continuous operations (the alarm will sound). When the water pump stops, restart it by switching the POWER switch off and on. Once all the diluted de-scaling liquid is transported into the boiler, turn off the POWER switch immediately.
  7. Submerge the tip of the water suction line into the container filled with 2 liters of clean tap water and turn on only the POWER switch to run the water pump. Once water starts coming out of the steam outlet, turn off the POWER switch and close the steam outlet valve. The clean tap water is to wash out the water pump.
  8. Let the machine sit for the time instructed on the de-scaling liquid label. Do not exceed the recommended time to avoid boiler damage.
  9. Drain the boiler vessel by opening the Y-strainer valve. If necessary, open the cap on the Y-strainer and temporarily remove the strainer to prevent scale from clogging the line (Fig. 23)

Fig. 23

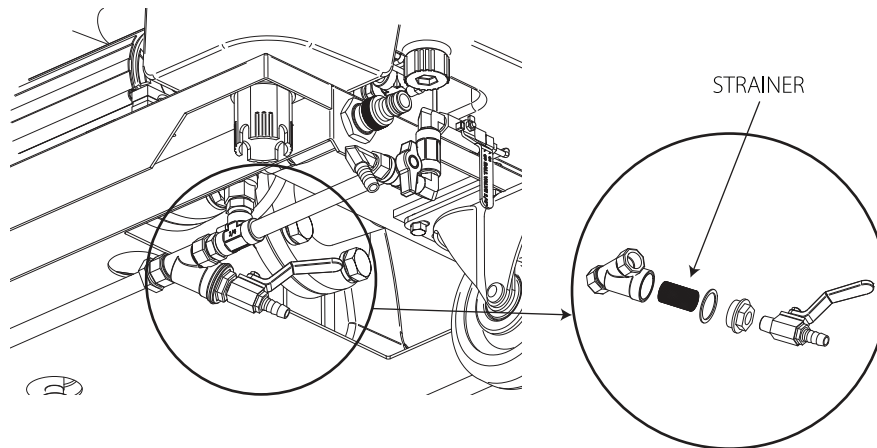

10. To wash out the boiler vessel and lines, supply clean water to the steam outlet valve until you cannot see scale coming out of the Y-strainer (Fig. 24).
11. Reassemble the Y-strainer and water suction line and connect the high water probe sensor to the wiring.

Fig. 24

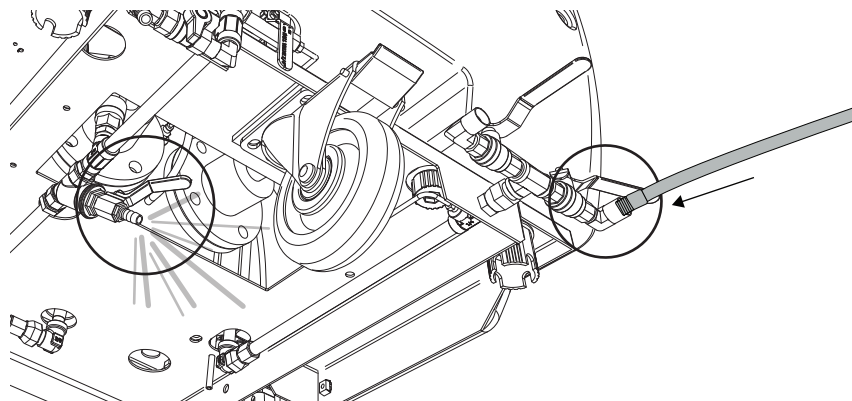

**Note!**

Check local regulations regarding the disposal of de-scaling liquid. Depending on the de-scaling product used, a special disposal method may be required.



## Safety Features

---



The Optima was designed with operator safety in mind. There are multiple safety features that protect both the operator(s) and the Optima. Understanding the Optima's safety features will enhance the user experience and assist you when troubleshooting.

### The Optima's Main Safety Features

- 1. Pressure control switch:** The pressure switch is set to 8 bars (adjustable from 0 to 10). The heaters will shut off if boiler pressure exceeds the preset pressure and will automatically reactivate when pressure decreases below 7 bar. (Fig. 25)
- 2. Temperature control:** The boiler will shut off if the steam temperature in the boiler vessel exceeds the maximum limit of 200 °C (392 °F). (Fig. 26)
- 3. Safety valve:** Pressure is released when boiler pressure exceeds 13 bar (Fig. 4-11).
- 4. The low water probe sensor:** The sensor prevents the heaters from heating up without sufficient water in the boiler vessel (Fig. 10).
- 5. Non-return valves:** Two non-return valves prevent steam from back drafting. (Fig. 1-6, 3-3)
- 6. Y-strainer:** The Y-strainer is connected to the boiler vessel drain. It is designed to break first before other important parts when a freeze rupture occurs (Fig. 1-4).
- 7. Water pump running time:** The water pump is programmed to shut off after running for 1 minute in order to avoid damage due to a dry run.

### Conditions for the heaters to Activate:

1. The POWER (HEATER 1) and HEATER 2 switch is on; **and**
2. The float switches in the water tanks detect liquids; **and**
3. The low water probe sensor in the boiler detects water; **and**
4. The steam pressure should not be above 7 bar; **and**
5. Boiler temperature should not be higher than 200 °C.

### Conditions for the Water Pump to Activate:

1. The POWER (HEATER 1) switch is on; **and**
2. Water is filled above the float switch level in the water tank; **and**
3. Water is not detected by the high water probe sensor; **and**
4. The water pump has not been running over 1 minute.

Fig. 25

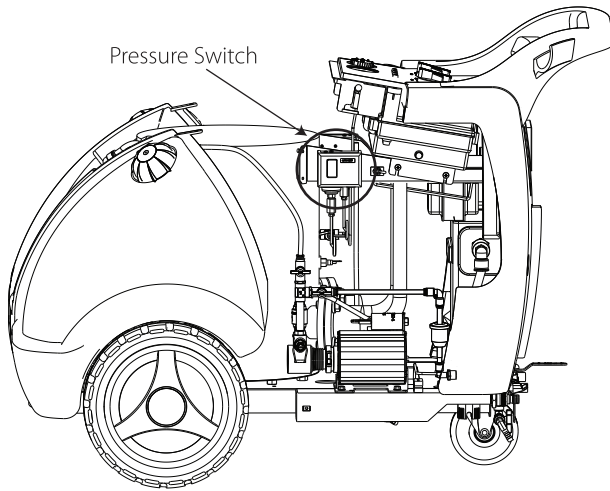
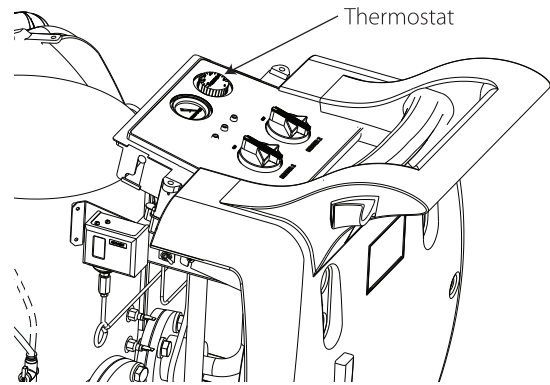

Fig. 26



**Note!**

Pressure Increase above 8 bars

Generally speaking, unexpected high pressure is generated due to compressed steam or water in the boiler vessel. When steam pressure gauge indicates above 8 bars, you must confirm the cause and take steps necessary before operating the machine again. See "Troubleshooting Guide" reference No.7 and 8.

**Steps**

1. Check if the boiler is activated(on)

The first step to take is to verify the origin of high pressure. To do so, check if the boiler is activated (on) or not. If the boiler is activated, you will see a flame inside the boiler chamber and feel warm air coming out from the flue (⚠️Do not put hands directly above the boiler flue.)

2. (a) The boiler is on.

**Cause and Remedy**

Turn off the POWER switch. The pressure gauge or the steam pressure switch is likely to be out of order → Contact your distributor (See "Troubleshooting Guide" reference No. 12).

- (b) The boiler is off









**Cause and Remedy**



Release internal pressure by opening the steam outlet valves and pulling steam gun trigger(s). While the low probe water sensor is functioning, the high probe water sensor does not sense water even when the water is filled above the high water probe sensor level. In this case, water will continue to be supplied to the boiler vessel, and the pressure will increase due to increased water volume (amount) in the confined boiler vessel space. → Clean the high level prove sensor or replace if necessary (See "Troubleshooting Guide" reference No. 7).

# Troubleshooting Guide



When a malfunction occurs, refer to the troubleshooting guide below. If the problem persists, please contact your local distributor and report the problem by referring to the reference number on the left hand side. See page 27 for instructions on disassembling.



## LED Lamps Indication

	Main POWER lamp on.		Water pump run lamp on
	Low water level lamp on.		Low water level lamp blinking
	Continuous pressure increase over 8 bar.		Continuous pressure decrease.
	Alarm beeps once.		Alarm continuously beeping.
	Electric Heater		

No	Lamps & Alarm Indications	Description, Cause
		Remedy
1		<p>No lamps on and no alarm sound when turning on the POWER switch due to;;</p> <ol style="list-style-type: none"> <li>1) No power supply</li> <li>2) Blown fuse (F1)</li> </ol> <p>1) Check your electrical power source. 2) Replace the fuse (F1). (Fig. 3-⑪)</p>
2		<p>The POWER switch is turned on. The POWER lamp is on and the alarm beeps once.</p> <p>This is a normal indication that occurs when the POWER switch is on.</p>
3		<p>Float switch is not detecting water in the water tank due to:</p> <ol style="list-style-type: none"> <li>1) Water shortage; OR</li> <li>2) Malfunction of the float switch in the tank.</li> </ol> <p>1) Add water to the water tank. (Fig. 6) 2) Disconnect the wire from the float switch. If the signal clears, replace the float switch.(Fig. 2-⑦)</p>

		<p>Water pump ran over the running time limit of 1 minute for the reason that the high water probe sensor cannot detect water in the boiler vessel because:</p> <ol style="list-style-type: none"> <li>1) Not enough water is being supplied to the boiler vessel; OR</li> <li>2) High water probe sensor cannot detect water despite the presence of water in the boiler; OR</li> <li>3) Water pump is out of order.</li> </ol> <ol style="list-style-type: none"> <li>1) Reset the water pump by switching the POWER switch off and on again. The alarm will clear once water reaches the high water probe sensor.</li> <li>2) Clean the high water probe sensor with sandpaper or replace it.</li> <li>3) Check if the water pump and motor are functioning. If no water movement is visible in the water suction lines and filter (Fig. 3-①,⑥), contact your distributor.</li> </ol> <p><b>Note!</b> If the high water probe sensor cannot detect the presence of water, water will continue to be supplied to the boiler vessel and cause an increase in pressure. When the water pressure reaches 13 bars the pressure safety valve located outside the boiler will discharge excess pressure and water. Clean or replace the high water probe sensor before resuming operation. (See Troubleshooting Guide's reference No. 7).</p>
4		<p>Float switch in the water tank cannot detect water and the low water probe sensor in the boiler cannot detect water simultaneously due to:</p> <ol style="list-style-type: none"> <li>1) Water shortage in both the water tank and the boiler vessel; OR</li> <li>2) Malfunction of the float switch in the water tank and/or low water probe sensor; OR</li> <li>3) Frozen or ruptured water float switch and/or low water probe sensor.</li> </ol> <ol style="list-style-type: none"> <li>1) Add water to the water tank (Fig. 6)</li> <li>2) Disconnect the wire from the float switch. If the signal clears, replace the float switch (Fig. 2-⑦). If the alarm persists, check the low water probe sensor. (See Troubleshooting Guide's reference No. 5)</li> <li>3) Defrost at room temperature and replace damaged parts. (See "Freeze Prevention" on page 15~16)</li> </ol>

5		<p>Low water probe sensor cannot detect water in the boiler vessel because:</p> <ol style="list-style-type: none"> <li>1) No or not enough water is present in the boiler; OR</li> <li>2) The low water probe sensor is malfunctioning; OR</li> <li>3) Steam is consumed faster than can be replenished; OR</li> <li>4) Water pump is out of order. OR</li> <li>5) Water temperature is lower than 5 °C</li> </ol> <ol style="list-style-type: none"> <li>1) Fill the water tanks, and wait up to 1 minute, allowing the water pump to supply water into the boiler vessel. Reset POWER. Repeat 1-2 times until the problem clears. If the problem persists, check other causes.</li> <li>2) Clean the low water probe sensor with sandpaper or replace. (See page 18 on how to test low water probe sensor)</li> <li>3) Close moisture control valve by 1/3.</li> <li>4) Check the pump or motor. Replace it if needed.</li> <li>5) Supply the feed water over 5 °C</li> </ol>
6		<p>Water pump runs over the running time limit of 1 minute for the reason that the low water probe sensor cannot detect water in the boiler vessel because:</p> <ol style="list-style-type: none"> <li>1) Not enough water is being supplied to the boiler vessel; OR</li> <li>2) Low water probe sensor cannot detect water despite the presence of water in the boiler vessel; OR</li> <li>3) Water pump is out of order.</li> </ol> <ol style="list-style-type: none"> <li>1) Reset the water pump by switching the POWER switch off and on again. The alarm will clear once water reaches the low water probe sensor.</li> <li>2) Clean the low water probe sensor with sandpaper or replace (See page 18 on how to test the low water probe sensor).</li> <li>3) Check if the water pump and motor are functioning. If no water movement is visible in the water suction lines and filter (Fig. 3-①,⑥), contact your distributor.</li> </ol>
7		<p>Water pump continues to run because the high water probe sensor does not detect water in the boiler vessel. When the water pressure reaches 13 bars, the pressure safety valve (Fig. 4-⑪) located outside the boiler will discharge excess water.</p>

		Disconnect the wire from the high water probe sensor and ground it to the boiler. If the pump stops the high probe sensor, needs to be cleaned or replaced (See "Maintenance" E on page 18).
8		The heaters remains on after boiler pressure increases over 8 bars (See page 21) due to: 1) Malfunction of pressure switch; OR 2) Malfunction of pressure gauge.  Turn off the POWER switch <b>immediately</b> . Check to see if the pressure switch is set to 8 bars. Reset the pressure switch to 8 bars with a differential value at '1'. (Fig. 25) If the pressure switch seems normal, Contact your distributor.
9		Unable to build pressure although the heaters are on.  1) Malfunction of pressure gauge; OR 2) Turn off the POWER switch immediately. Contact your distributor.
10	The water tanks become hot <b>or</b> damage the water suction /delivery line of the pump <b>and</b> the steam pressure drops.	Hot water in the boiler traveled backwards into the water tank due to leak both the non-return valves.  Clean or replace the non-return valves (Fig. 1-⑥, 3-③)
11	Water is draining from underneath the machine	Y-strainer has cracked due to freezing.(Fig. 1-④). (See page 21)  Thaw the machine at room temperature. Inspect it for additional damages. Replace the Y-strainer and other damaged part(s) if any. (See "Freeze Prevention" on page 15~16)
12	I can feel static electricity on the spray gun or on the machine.	The machine is not grounded properly.  Ensure that the machine is grounded using the grounding chain located at the bottom of the machine. (Fig. 4-③)

---

## • Disassembling Exterior Covers

When the disassembling of covers is required for maintenance or troubleshooting, follow steps below. Use the tools provided by your distributor or the manufacturer.

What you will need : The tools provided by the manufacturer or your distributor.

### Steps (Fig. 27)

1. Undo the top cover by unscrewing 4 bolts with a screw driver (+).
2. Unscrew the 2 bolts on the top side of both side covers.
3. Use a T-Type wrench (10mm) to loosen the bolt located in a hollow surface at the bottom of each side cover.

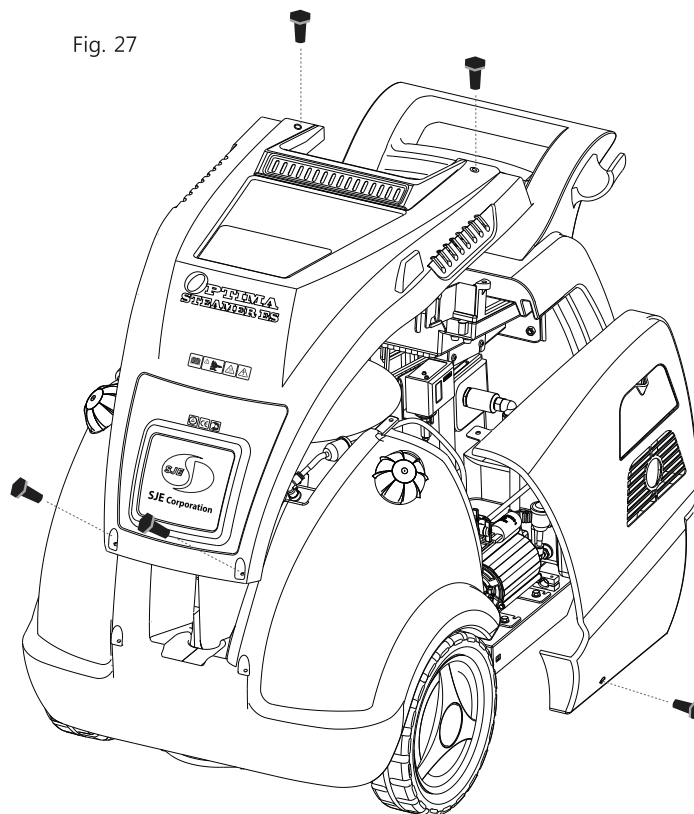



**SJE Corporation, Ltd.**  
Global Leader of Green Solutions

**[Head Office]**

San 225 Yelim-Li, Jeonggwan-Myeon, Gijang-Gun Busan, South Korea

**[Busan Office]**

568-3 Myeongjang-dong, Dongnae-gu, Busan, South Korea / tel : +82-51-521-3200 / Fax : +82-51-521-3305

**[US Office - Steamerics, Inc]**

20620 S. Leapwood Ave., Ste. E, Carson, CA 90746, United States / Tel : +1-310-327-8900 (US Office)

e mail : [info@sjecorp.com](mailto:info@sjecorp.com)

<http://www.sjecorp.com>